

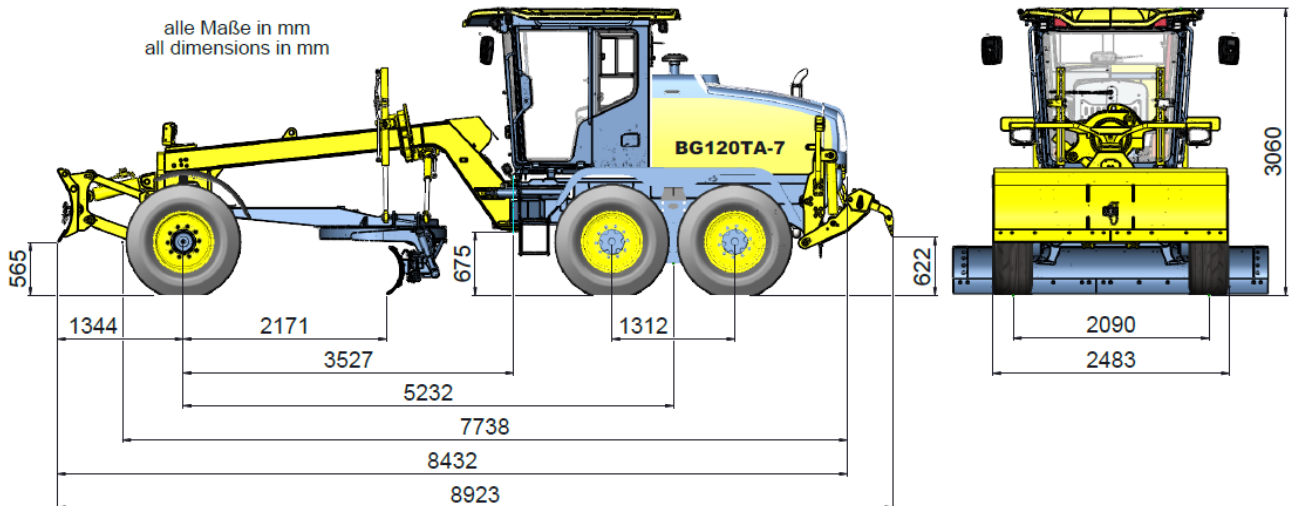

Motor Grader

BG 120 T-7 (6x4) / BG 120 TA-7 (6x6)



Engine Data

Make/Model	PERKINS diesel engine 1204J-E44TA with DOC, DPF, SCR technology (DEF/AUS 32/AdBlue),
Emission standard	EU Stage 5 / U.S. EPA Tier 4 final / Japanese MOC/MLIT NONROAD Step 4 Final
Type	water-cooled, four-stroke cycle, direct injection, turbocharged and intercooled
Rated net horsepower (ISO 14396) at 2200 rpm	110,1 kW / 149,7 MHP
Rated Torque (max.)	560 Nm at 1400 rpm
No. of cylinder	in line 4
Bore & stroke	105 x 127 mm
Displacement	4,4 litres

Engine equipped with dry air filter with safety cartridge and dust ejector. Electronic controlled viscose radiator fan. 24 volt starting and electrical system. 80 amp alternator and 24 volt starter with 4,5 kW (6,1 HP). 2 batteries 74 Ah each.



Operating Weight

Total weight	approx. 14000 kg
On rear wheels	approx. 10000 kg
On front wheels	approx. 4000 kg

Weights shown include cab, all operating fluids, rear ripper (width 2120 mm), front dozer blade.



All-Wheel Drive System (TA Type)

Hydrodynamic rear axle drive with 6-speed Ergopower transmission and torque converter (make ZF 6 WG 115) with freely selectable microprocessor controlled hydrostatic front axle drive. Power train is controlled appropriate to tyre traction.



Rear Axle Drive System (T type)

Hydrodynamic rear axle drive with 6-speed Ergopower transmission (make ZF 6 WG 115) and torque converter.



Speeds

(All-Wheel Drive and Rear Axle Drive Systems)

Forward	km/h
1.	5.0
2.	7.0
3.	12.0
4.	19.0
5.	28.0
6.	40.0
Reverse	
1.	6.0
2.	14.0
3.	32.0

Acoustic back-up alarm in reverse driving



Rear Axle

Oscillating tandem axle with axle insert.
No-Spin differential.
Multi-disc brakes in all four wheel hubs.
Parking brake at powershift transmission.



Tandems

Drive via roller chains.	
Torsion-proof box sections.	
Height	545 mm
Width	178 mm
Thickness of walls	20/20 mm
Wheel base	1312 mm
Oscillation	±15°
Ground clearance	350 mm



Wheels & Tyres

Tyre size	455/70 R24 radial
Rim size	13.00 x 24



Brakes

Service brake

Dual-circuit, power-assisted, multi-disc oil-bath type, effective on four wheels. Includes reserve power and operator warning system.

Parking brake

Independent electrically operated brake, acting on rear axle. Hydraulic spring accumulated single disc type.



Front Axle

2 types are available

Oscillation	15° up and down
Steering angle	45°
Wheel lean	±17°
Ground clearance	530 mm

Non driven with wheel lean (T type)

Stable welded steel beam with wheel lean.

Driven with wheel lean (TA type)

Stable welded steel beam with wheel lean.

Radial piston engines in wheel hubs.

Pulling power electronically adjustable (infinitely variable depending on surface conditions.).

Possibility to fit in the hydraulic differential lock.



Steering

Hydraulic power steering	
Minimum turning radius without dozer blade	6350 mm
Minimum turning radius with dozer blade	7000 mm
Steering angle	45°



Frame

Front and rear frame sections are connected with an adjustment free articulation pin.

Front: Fully welded rear box section.

Minimum dimensions of box section	240 x 240 mm
Plate thickness	20/12 mm

Rear: Fully welded rear frame

Dimensions (solid main bars)	430 x 60 mm
------------------------------	-------------

Hydraulic articulated frame steering (right & left)	30°
-----------------------------------------------------	-----



Circle (closed version)

Hardened teeth, machine-cut on inside of circle for maximum strength and minimum wear. The circle is held positively in place by an adjustment free roller bearing.

Diameter	1348 mm
Tooth width	78 mm
Height	130 mm



Circle Drive

Hydraulically driven worm gear transmission. Circle drive system fully protected against impact damage by an overload clutch.

Rotation	360°
----------	------



Drawbar

A-shaped fully welded construction.

Dimensions (solid sections)	30 x 170 mm
-----------------------------	-------------



Moldboard (standard)

Moldboard (11 ft)	3355 x 505 x 15 mm (11' x 19,9" x 0,6")
Blade material	High carbon steel
Blade pull (at a friction factor of 0.8)	BG 120 T-7 78.8 kN BG 120 TA-7 98.8 kN



Blade Range

Reach outside tyres without articulation (RH&LH), blade resting on levelled surface	2050 mm / 1200 mm
Reach outside tyres with articulation (RH&LH), blade resting on levelled surface	2530 mm / 1680 mm
Circle shift	1140 mm
Blade side shift	1000 mm
Blade tilt range	40°- 80°
Bank sloping angle (RH&LH)	90°
Lift above ground	495 mm
Cut below ground	365 mm
Distance blade/front axle	2170 mm

All blade movements and positions can be controlled from the operator's seat.



Capacities

Fuel	220.0 litres
Hydraulic oil	170.0 litres
Engine oil	9.0 litres
Ergopower transmission	32.0 litres
Axle drive rear	13.5 litres
Planetary gears and brakes	4 x 4.0 litres
Tandem case (2 x 18 litres)	36.0 litres
Circle drive	6.0 litres
Coolant	34.0 litres
DEF (AUS 32/AdBlue)	20.0 litres



LED Light Equipment

2 headlights at the front, every 2 indicator lights (including hazard warning lights) at the front and rear, 2 rear lights, 2 brake lights, 1 backup light, every 2 working lights at the top and bottom at the front of the cab, 2 working lights at the top at the rear of the cab, and 2 tail lights on the sides.



Load-Sensing Hydraulics

The control valves of the working hydraulics may be actuated at a time and independent of each other. The load-sensing pump (axial piston pump) discharges only the required quantity of oil if a control valve is actuated. When hydraulic power is not required, the system pressure is only 24 bar and ensures low oil temperature and fuel saving.

Lock valves and brake valves prevent a cylinder drift under load.

Operating pressure 205 bar
max oil flow 132 l/min



Cabin (tiltable)

Integrated ROPS/FOPS cabin mounted on isolators to limit vibration and noise entering the cabin. Excellent all-round visibility. Roomy and comfortable. Adjustable steering pedestal with EURO control lever arrangement. Interior of cab fully lined, floor covering. Tinted safety glass windows.

Sliding doors and windows LH and RH.

Fresh air heating with pre-filter, air circulation, air conditioning (A/C). Adjustable, air-suspended driver's seat with safety belt. One inside mirror as well as two electrically operated adjustable and heatable outside rearview mirrors.

Wipers front and rear, with front window washer

Blinds front and rear.

Rear view camera system.

Height / Width / Depth (cabin inside) 1620 / 1450 / 1480 mm



Optional Equipment

EP control panel (Joystick controls)

Auxiliary heating

Automatic climate control (A/C)

Recording speedometer

Cooling box

Stereo radio various (CD player, Bluetooth, DAB+)

Protective grids for cabin and lights

Moldboard (10 ft) 3050 x 505 x 15 mm (10' x 19,9" x 0,6")

Moldboard (12 ft) 3660 x 505 x 15 mm (12' x 19,9" x 0,6")

Cover plate for upper guide rail of moldboard

Moldboard extensions, RH/LH (1 ft) 305 mm

Adjustable moldboard corner shoes, RH/LH

Float position for both moldboard lift cylinders

Towing device, tiltable, 12V / 24V

Wheels and tyres

Tyre size 13.00-24 diagonal

Rim size 10.00 x 24

Tyre size 405/70 R24 radial

Rim size 13.00 x 24

Other tyres on request

Front dozer blade with position indicator

Width/Height 2490 x 780 mm

Cut below ground 150 mm

Lift above ground 565 mm

Weight 840 kg

Rear ripper with depth penetration indicator, 4 teeth (max. 7)

Width 2120 mm

Ripping depth 260 mm

Lift about ground 450 mm

Weight 610 kg

Counter weight (push-pull block), in front 556 kg

Mudguards on front wheels

Mudguards on rear wheels

Protective covers for transmission in different versions

Central lubricating unit

Biological oil in hydraulic system

Electric fuel tank pump with automatic switch-off

Special paint

Beacon (orange)

Tool kit, wheel chocks, warning triangle, fire extinguisher, first aid kit

Automatic blade control

Various 2D / 3D / GPS systems

CE Certificate

Speed limitation at 20 km/h possible

Further options on request

